

VRAJLINK

AUTHORIZED DEALER & DISTRIBUTORS

Address :- Shop No. 17, Opp. Electric Crematorium, 66/74 Chandan Wadi, Marine Lines (E), Mumbai - 400002

Email :- vrajlink09@gmail.com

Contact :- 9223310978 / 9833935831

Website :- www.vrajlink.com

TransferPacT -Transfer Switching Equipment



se.com

Life Is On

Schneider
Electric

TransferPacT Automatic Product Family



Codes and standard

- IEC 60947-1 General rules
- IEC 60947-6-1 Transfer switching equipment
- GB 14048.1 General rules
- GB/T 14048.11 Transfer switching equipment



Certifications and declarations

- CB certification
- CE certification
- CCC certification
- UKCA declaration
- EAC declaration



Certifications and declarations

- TransferPacT ATSE can operate in an ambient temperature of -25°C ~ +70°C
- The altitude of the installation site shall not exceed 2000 m
- When the highest temperature is +55°C, the relative humidity in air shall not exceed 95%
- Storage temperature: -35°C ~ +85°C



Vibration and Shock

- Tests are carried out in compliance with IEC 60068-2-6 and IEC 60068-2-27

Electromagnetic compatibility (EMC)

- EMC Class A
- EMI Class B
- Electrostatic discharge Level 4
- Radio-frequency electromagnetic field Level 3
- Fast transient bursts Level 4
- Surges Level 4
- Harmonic wave Level 3
- Voltage dips and short-time interruptions Level 3

Degree of Pollution

- Pollution degree 3 as defined by IEC standard 60947

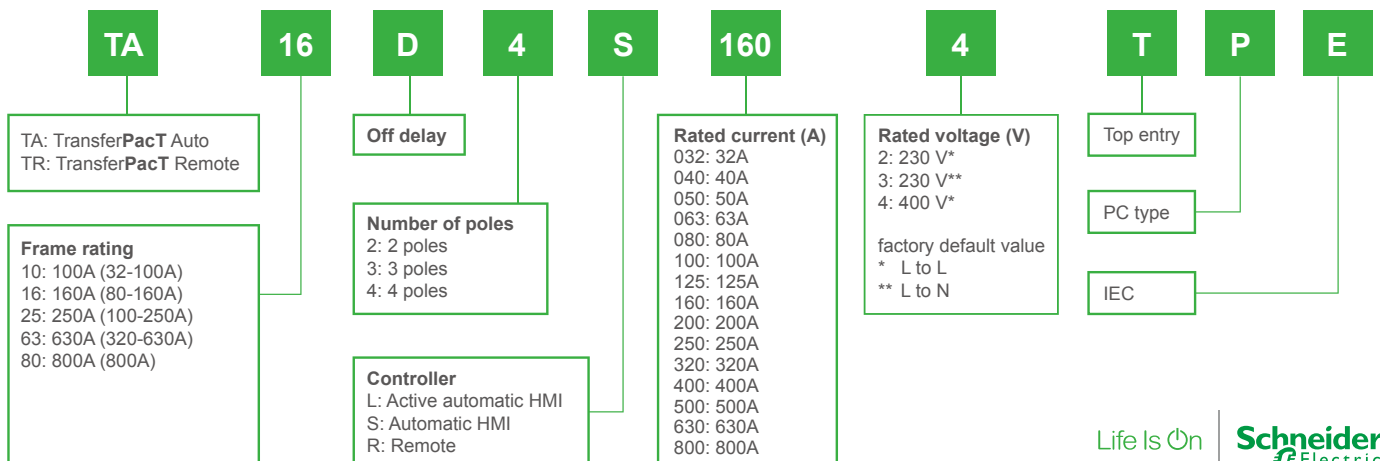

TransferPacT Switch Functions and Characteristics

Frame	100A	160A	250A	630A	800A
Type of device	Non-derived TSE PC type	Non-derived TSE PC type	Non-derived TSE PC type	Non-derived TSE PC type	Non-derived TSE PC type
Suitable for isolation	■	■	■	■	■
Electrical Characteristics					
Current rating (Ampere)	32,40,50,63,80*,100* *: AC-32B for 80A and 100A	80,100,125,160	100,160,200,250	320,400,500,630	800
Rated operational voltage	2P:220/230/240/ 250V L-N 3P,4P:380/400/ 415/440V L-L	3P,4P:380/400/ 415/440V L-L	3P,4P: 208/220/ 230/240V L-L 380/400/415/440V L-L	3P,4P: 208/220/ 230/240V L-L 380/400/415/440V L-L	3P,4P: 208/220/ 230/240V L-L 380/400/415/440V L-L
Number of poles	2,3,4	3,4	3,4	3,4	3,4
Frequency	50 Hz/60 Hz	50 Hz/60 Hz	50 Hz/60 Hz	50 Hz/60 Hz	50 Hz/60 Hz
Insulating voltage U_i (V AC) switch only	800V	800V	800V	800V	1000V
Impulse withstand voltage U_{imp} (V AC) switch only	6kV	8kV	8kV	12kV	12kV
Rated short-circuit making capacity I_{cm} (kA)	Switch alone	15kA	20kA	30kA	40kA
	with Upstream Circuit Breaker	75kA	154kA	330kA	330kA
Rated short-time withstand current I_q (kA) with Circuit Breaker	50kA(2P:25kA)	70kA	150kA	150kA	150kA
Rated short-time withstand current I_q (kA) with fuse	100kA	100kA	200kA	200kA	200kA
Rated short-time withstand current I_{cw} (kA)	5kA/0.1s	10kA/0.1s	10kA/0.5s, 15kA/0.1s	25kA/0.1s, 20kA/ 0.5s, 15 kA/1 s	20kA/0.1s, 20kA/ 0.5s, 15 kA/1 s
Utilization category	AC-33B	AC-33B	AC-33B	AC-33B	AC-33B
Operating temperature	-25°C to +70°C	-25°C to +70°C	-25°C to +70°C	-25°C to +70°C	-25°C to +70°C
Operational Characteristics					
Overvoltage category	III	III	III	III	III
Maintenance Mechanical durability	8000 cycles	10000 cycles	10000 cycles	10000 cycles	10000 cycles
Additional Indication and Control Auxiliaries					
Auxiliary contacts for N and A position	□	□	□	□	□
Auxiliary contacts for OFF position	□	□	□	□	□
Installation and Connection					
Fixed top connection	■	■	■	■	■
Installation method	DIN Rail/Base Plate	DIN Rail/Base Plate	Base Plate	Base Plate	Base Plate
Installation and Connection Accessories					
Terminal shields	□	□	□	□	□
Inter-phase barriers	-	□	□	□	□
Power Connections	□	□	□*	□*	□*
Shipping Information					
Net weight kg	3.4	5.6	13.3	22.1	22.4
Dimension L*W*D mm	155* 310* 94.3	164* 351* 95	370* 341* 186	467* 341* 186	467* 341* 186

* Refer to the power connection for more details.

NOTE:

- : Solid green square represents standard function.
- : Hollow square represents optional function.

TransferPacT Controller

Controller type		Active Automatic version with LCD display	Automatic version with rotary switch	Remote version without HMI
Installation		Embedded controller	Embedded controller	Not Applicable
Controller Functional Characteristics				
2P		230V: can be set at 220V/240V/250V(Line to Neutral voltage. Available for Frame 100)	230V: can be set at 220V/240V/250V(Line to Neutral voltage. Available for Frame 100)	
3P / 4P		230V: can be set at 208V/220V/240V(line to line voltage. Available for Frame 250 and 630)	400V: Can be set at 380V/415V/440V	230V:can be used under 208V/220V/240V(line to line voltage, for frame 250& frame 630)
		400V: Can be set at 380V/415V/440V		400V: can be used under 380V/415V/440V(line to line voltage, for frame 250& frame 630)
Rated operating frequency (Hz)		50/60	50/60	50/60
Rated insulation voltage (V)		500	500	500
Impulse withstand voltage (kV)		6kV	6kV	6kV
Operating temperature		-25°C to +70°Ca	-25°C to +70°C	-25°C to +70°C
Operating altitude		≤2000m	≤2000m	≤2000m
Protection degree		IP20	IP20	IP20
Pollution degree		3	3	3
Accuracy (for power deviation)	Voltage	1%	1%	Not Applicable
	Frequency	0.1%	0.1%	Not Applicable
Electrostatic discharge		Level 4	Level 4 ¹	Level 4
Radio-frequency electromagnetic field		Level 3	Level 3	Level 3
Fast transient bursts		Level 4	Level 4	Level 4
Surges		Level 4	Level 4	Level 4
Harmonic wave		Class 3	Class 3	Class 3
Voltage dips and short-time interruptions		Class 3	Class 3	Class 3
Vibration		IEC 60068-2-6	IEC 60068-2-6	IEC 60068-2-6
Shock		IEC 60068-2-27	IEC 60068-2-27	IEC 60068-2-27
Display of Controller				
Display mode		LCD+LED+Indicator	Rotary switch+DIP switch+LED+Indicator	LED+Indicator
Single line diagram		■	■	■
Language		English/Chinese/French/Russian/Spanish/Italian/German/Portuguese	Not Applicable	Not Applicable
Power status		■	■	■ power/mode display
Position for contact		■	■	Not Applicable
Set value		Button	Rotary switch+DIP switch	Not Applicable
Control Mode				
Auto	Auto return	■	■	Not Applicable
	Non return	■	■	Not Applicable
Non-Auto	Handle	■	■	Not Applicable
	Forcev	□	□	Not Applicable
	Fire	□	□	Not Applicable
	Inhibit	□	□	Not Applicable
	Local	■	-	Not Applicable
	Voluntary	□	□	Not Applicable
	communication	■	-	Not Applicable
Test	■	□	Not Applicable	

TransferPacT Controller

Auto Control				
Sampling		Three Phase for both normal and alternate	Three Phase for both normal and alternate	Not Applicable
Voltage loss		<36V	<36V	<36V
Phase loss		L1, L2, L3	L1, L2, L3	Not Applicable
Under voltage	Set value	70% to 95%	4%,6%,8%,10%,12%,14%,16%,18%,20%	Not Applicable
Over voltage	Set value	105% to 135%	4%,6%,8%,10%,12%,14%,16%,18%,20%	Not Applicable
Under frequency	Set value	80% to 98%	2%,3%,4%,5%,6%,7%,8%,9%,10%	Not Applicable
Over frequency	Set value	101% to 120%	2%,3%,4%,5%,6%,7%,8%,9%,10%	Not Applicable
Unbalance of three phase voltage		2% to 30%	-	-
Phase rotation		Yes	-	-
Time Delay				
Transfer delay		0 to 30 minutes	U-U: 0,1,2,3,5,10,20,30,60s. U-G: 5s	-
Retransfer delay		0 to 60 minutes	0,1,2,3,5,10,20,30,60 min	-
Center of delay		0 to 30s	0 or 5s	-
Genset start delay		0 to 120s	0,1,2,3,5,10,20,30,60s	-
Genset cooldown delay		0 to 60 minutes	-	-
Loadshedding delay		0 to 15s	-	-
Genset ready alarm delay		15-300s	300s	-
Test delay:on load		1-1800s	-	-
Test delay:off load		1-1800s	-	-
Other Functions				
Calender time		<input checked="" type="checkbox"/>	-	-
Position feedback		<input type="checkbox"/>	<input type="checkbox"/>	<input type="checkbox"/>
Event log		<input checked="" type="checkbox"/>	-	-
Source priority		<input checked="" type="checkbox"/>	<input checked="" type="checkbox"/>	-
Communication		Modbus RTU	-	-
Transfer Inhibit		<input type="checkbox"/>	<input type="checkbox"/>	-
Password protection		<input checked="" type="checkbox"/>	-	-
Gen start-stop		<input type="checkbox"/>	<input type="checkbox"/>	-
Test		<input checked="" type="checkbox"/>	<input type="checkbox"/>	-
Load shedding		<input type="checkbox"/>	<input type="checkbox"/>	-
Fire protection		<input type="checkbox"/>	<input type="checkbox"/>	-
Failure lock		<input checked="" type="checkbox"/>	<input checked="" type="checkbox"/>	<input checked="" type="checkbox"/>
Alarm indication		<input checked="" type="checkbox"/>	<input checked="" type="checkbox"/>	<input checked="" type="checkbox"/>
External power supply port		<input checked="" type="checkbox"/>	-	-
Wrong connection of neutral alarm		<input checked="" type="checkbox"/>	-	-

1. Close the plastic cover.

Electrical and mechanical accessories

TransferPacT Automatic Function modules

	For Active Automatic and Automatic HMI	
	Load shedding and Availability warning	TPCDIO05
	Transfer inhibit and Remote testing	TPCDIO07
	Voluntary Remote control	TPCDIO08
	Fire Protection 24 Vdc pulse	TPCDIO10
	Fire Protection 24 Vdc constant	TPCDIO11
	Fire Protection 230 Vac constant	ATPCDIO13
	Fire Protection Dry contact	TPCDIO14
	Genset start and Alarm	TPCDIO17
	For Active Automatic HMI only (* Native equipped for TransferPacT active automatic. no need to order except for renewal or replace)	
	BUS Extension and 24 VDC auxiliary supply	TPCDIO15
Modbus RTU (Serial Port)	TPCCOM16	

TransferPacT Active Automatic External HMI

	1x	External HMI	TPCCIF04
	1x	HMI Cable 1m	TRV00810
		HMI Cable 2m	TRV00820
		HMI Cable 3m	TRV00830
	1x	IP54 cover (for outdoor installation)	TPCOTH37

TransferPacT Automatic spare part



	Active Automatic HMI	TPCCIF01
	Automatic HMI	TPCCIF02

Auxiliary contacts

	OF for Source position for frame 100 & frame 160	TPSAUX32
	OF for OFF position for frame 100 & frame 160	TPSAUX33
	OF for Source position for frame 250 & frame 630	TPSAUX43
	OF for OFF position for frame 250 & frame 630	TPSAUX44

Electrical and mechanical accessories

Insulation accessory

	Interphase barrier frame 160 (set of 9)	TPSISO29
	Interphase barriers for frame 250 (100-250A) and frame 630 (320-630A) (set of 3)	TPSISO65
	Terminal Shield for frame 100 (32-100A) (set of 2)	TPSISO30
	Terminal Shield for frame 160 (80-160A) (set of 3)	TPSISO31
	Terminal Shield for frame 250 (100-250A) (set of 1)	LV429518
	Terminal Shield for frame 630 (320-630A) (set of 1)	TPSISO42
	Insulating screen for frame 250 (100-250A) (set of 1)	TPSISO66
	Insulating screen for frame 630 (320-630A) (set of 1)	TPSISO67

Connection accessory-bare cable connector

	1 cable 25 mm ² to 95 mm ² , frame 250 (set of 3)	LV429227
	1 cable 25 mm ² to 95 mm ² , frame 250 (set of 4)	LV429228
	1 cable 120mm ² to 185mm ² , frame 250 (set of 3)	LV429259
	1 cable 120mm ² to 185mm ² , frame 250 (set of 4)	LV429260
	1 cable 120 to 240 mm ² , frame 250 (set of 3)	TPSCON49 ^b
	1 cable 120 to 240 mm ² , frame 250 (set of 4)	TPSCON50 ^b
	1 cable 35 to 300 mm ² , frame 630 (set of 3)	TPSCON53 ^b
	1 cable 35 to 300 mm ² , frame 630 (set of 4)	TPSCON54 ^b
	2 cables 50 to 120 mm ² , frame 250 (set of 3)	TPSCON51 ^{a,b}
	2 cables 50 to 120 mm ² , frame 250 (set of 4)	TPSCON52 ^{a,b}
	6 cables 1.5 to 35 mm ² , frame 250 (set of 3)	TPSCON47 ^b
	6 cables 1.5 to 35 mm ² , frame 250 (set of 4)	TPSCON48 ^b
	9 cables for frame 250 (set of 3)	LVS04033
9 cables for frame 250 (set of 4)	LVS04034	
	1 cable 1.5 to 95 mm ² , frame 250 (set of 3)	LV429242
	1 cable 1.5 to 95 mm ² , frame 250 (set of 4)	LV429243

a) Applicable for downstream only



b) Must select terminal shield to ensure incoming and output terminal protection

NOTE:

this brochure serves as a brief introduction of all the products and accessories within TransferPacT range. For usage restrictions of power connection accessories, please check LVPED216028EN or reach out to your local representative for more information.

Electrical and mechanical accessories

Connection accessory-crimp lug

	150 mm ² , frame 250 (set of 3)	LV429504
	150 mm ² , frame 250 (set of 4)	LV429505
	185 mm ² , frame 250 (set of 3)	LV429506
	185 mm ² , frame 250 (set of 4)	LV429507
	240 mm ² , frame 630 (set of 3)	TPSCON61
	240 mm ² , frame 630 (set of 4)	TPSCON62
	300 mm ² , frame 630 (set of 3)	TPSCON63
	300 mm ² , frame 630 (set of 4)	TPSCON64
	120 mm ² , frame 250 (set of 3)	LV429252
	120 mm ² , frame 250 (set of 4)	LV429256
	150 mm ² , frame 250 (set of 3)	LV429253
	150 mm ² , frame 250 (set of 4)	LV429257
	185 mm ² , frame 250 (set of 3)	LV429254
	185 mm ² , frame 250 (set of 4)	LV429258
	240 mm ² , frame 630 (set of 3)	TPSCON57
	240 mm ² , frame 630 (set of 4)	TPSCON58
	300 mm ² , frame 630 (set of 3)	TPSCON59
	300 mm ² , frame 630 (set of 4)	TPSCON60

Connection accessory-terminal extensions

	edgewise terminal extensions for frame 250 (set of 3)	LV429308
	edgewise terminal extensions for frame 250 (set of 4)	LV429309
	edgewise terminal extensions for frame 630 (set of 3)	TPSCON55
	edgewise terminal extensions for frame 630 (set of 4)	TPSCON56
	Straight terminal extensions for frame 250 (set of 3)	LV429263
	Straight terminal extensions for frame 250 (set of 4)	LV429264
	Spreader for frame 100 (set of 4)	TPSCON35
	Spreader for frame 160 (set of 4)	TPSCON36
	35mm-45mm Spreader for frame 250 (set of 3)	LV431563
	35mm-45mm Spreader for frame 250 (set of 4)	LV431564 ^b
	35mm-45mm Spreader for frame 250 (set of 4)	TPSCON39 ^a
	45mm-55mm Spreader for frame 630 (set of 3)	TPSCON40
	45mm-55mm Spreader for frame 630 (set of 4)	TPSCON41 ^a
	45mm-55mm Spreader for frame 630 (set of 4)	TPSCON68 ^b

a) For incomings only

b) For load only

NOTE:

this brochure serves as a brief introduction of all the products and accessories within TransferPacT range. For usage restrictions of power connection accessories, please check LVPEd216028EN or reach out to your local representative for more information.

TransferPacT Dimensions

Frame 100/2P, 3P, 4P

Dimensions

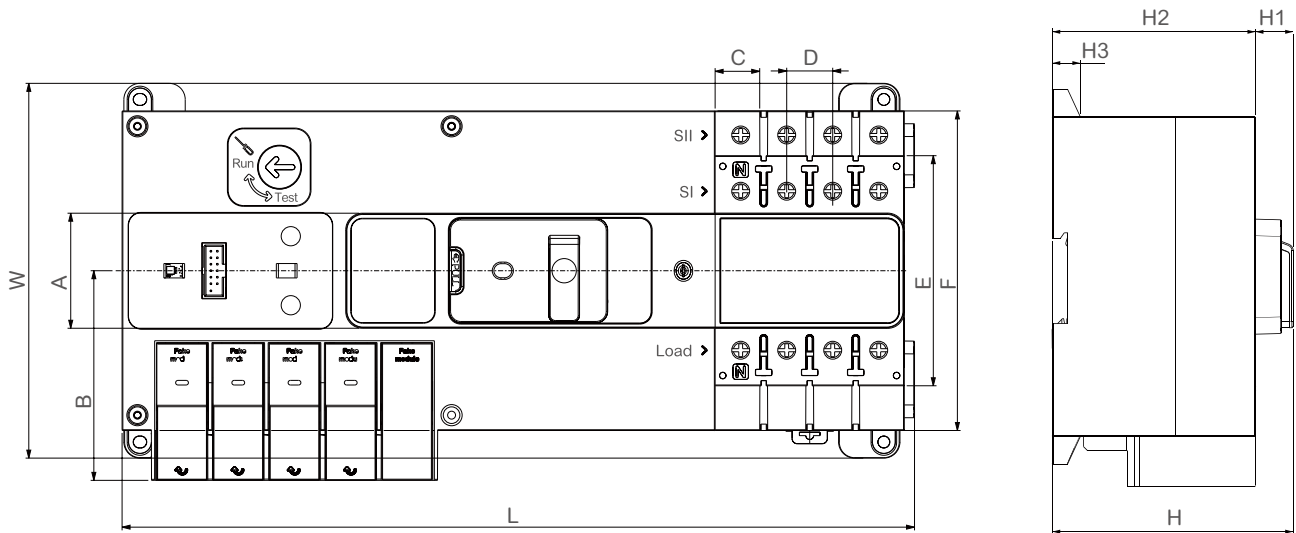

Panel and Front panel cut

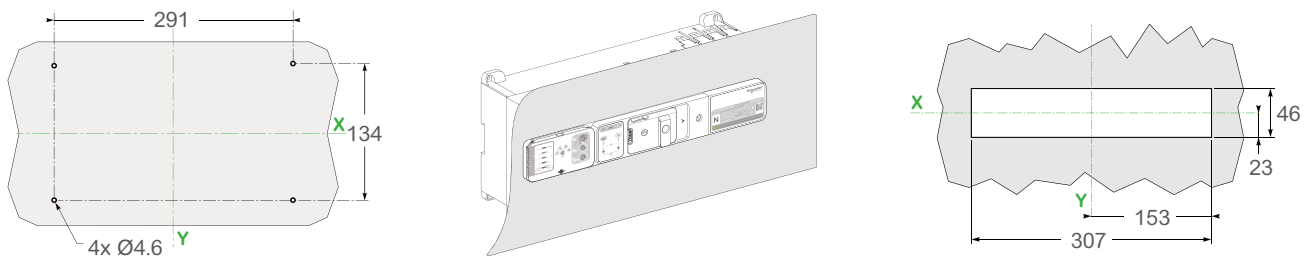

Frame	L	W	H	A	B	C	D	E	F	H1	H2	H3
100	310	147	94	45	82	17.5	18	90	125	15	79.5	11

TransferPacT Dimensions

Frame 160 / 3P, 4P

Dimensions

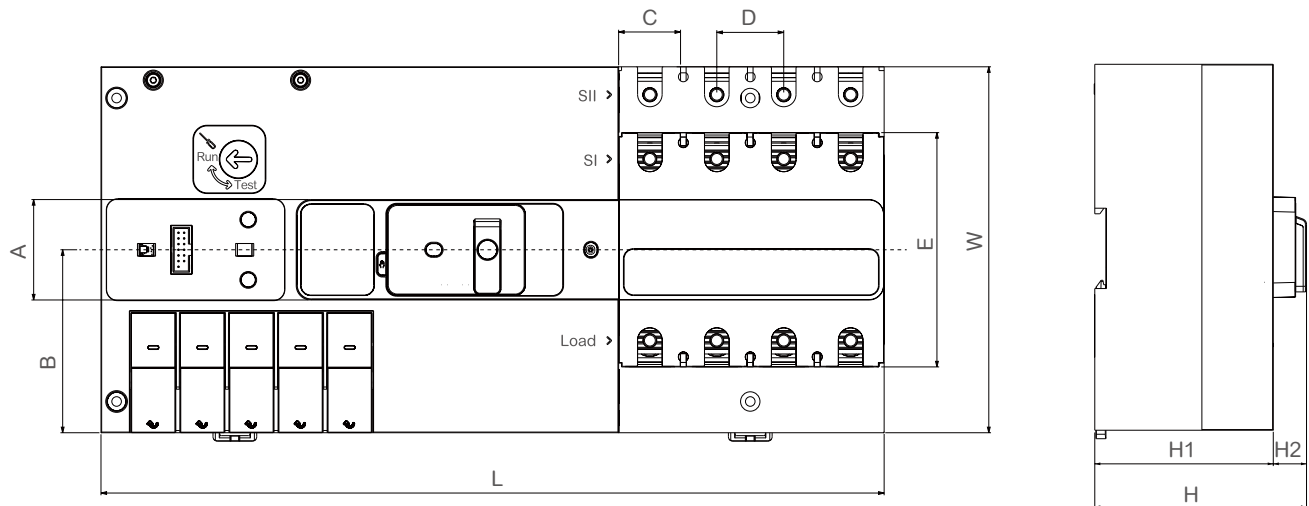

Panel and Front panel cut

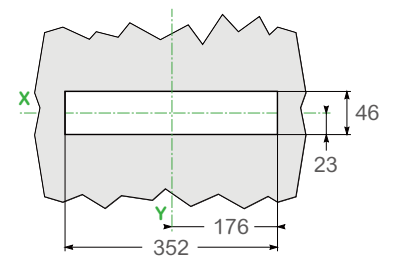
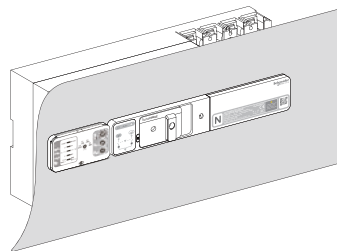
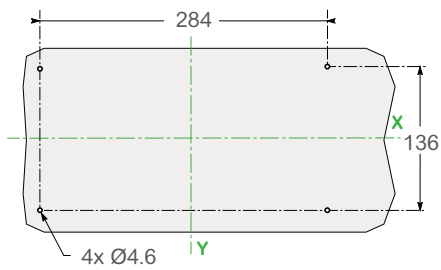

Frame	L	W	H	A	B	C	D	E	F	H1	H2	H3
160	351	164	95	45	82	28	30	105		80	15	

TransferPacT Dimensions

Frame 250/3P, 4P

Dimensions

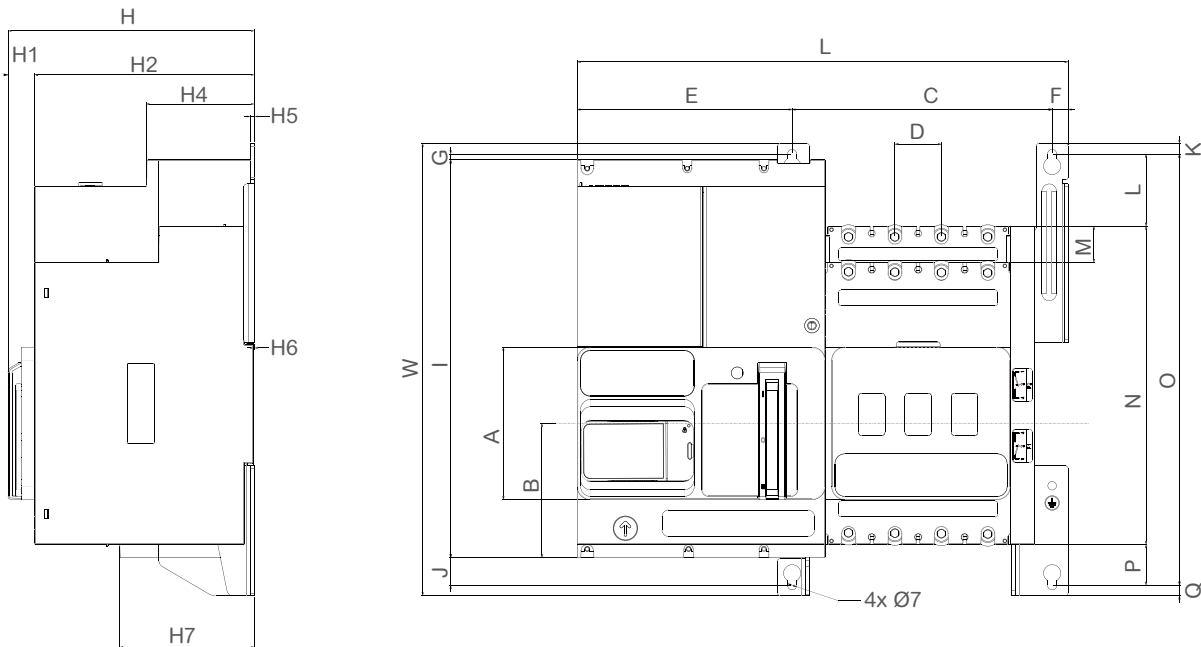

Panel and Front panel cut

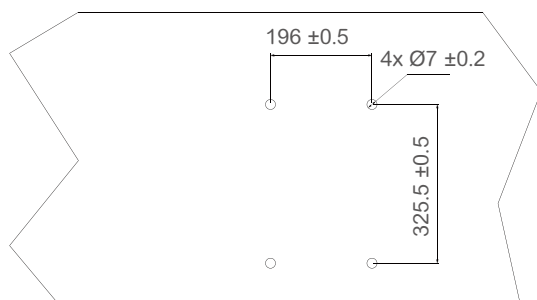

Backplane

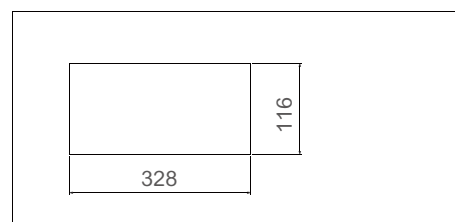

Cutout

Frame	L	W	H	A	B	C	D	E	F	G	H	H1	H2	H4	H5	H6	H7
250	341	300	185.8	115	101.3	196	35	162	12	4.3	185.8	20.1	185.7	81.75	3	0.7	101.7

Frame	I	J	K	M	N	O	P	Q
250	300	20.7	8	27.3	240	325	30.7	8

TransferPacT Dimensions

Frame 630/3P, 4P & Frame 800/3P,4P

Dimensions

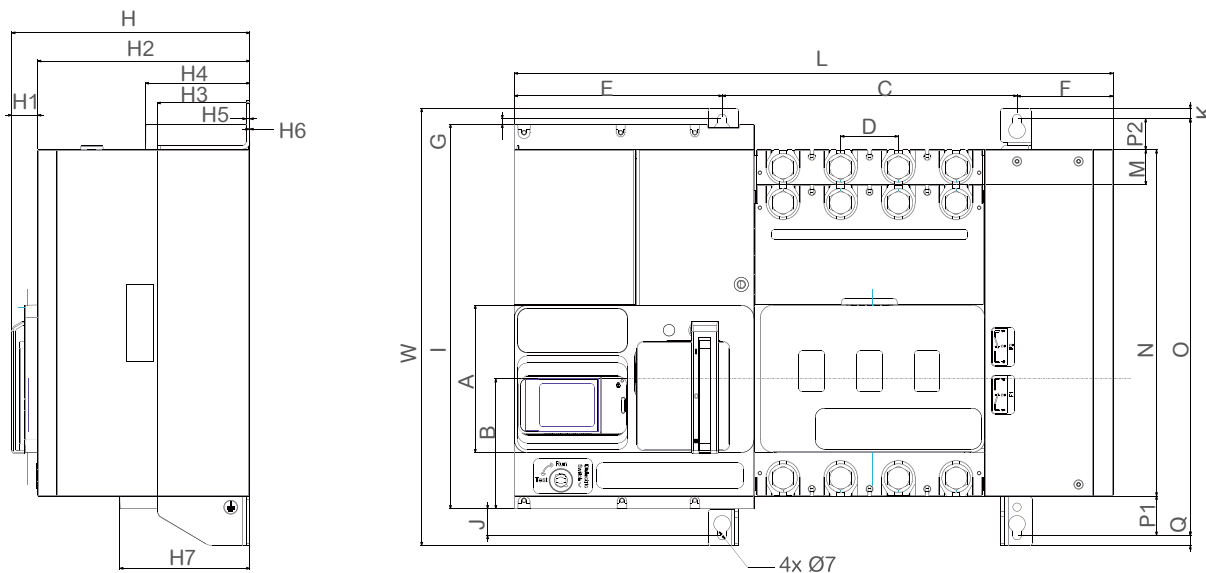

Panel and Front panel cut

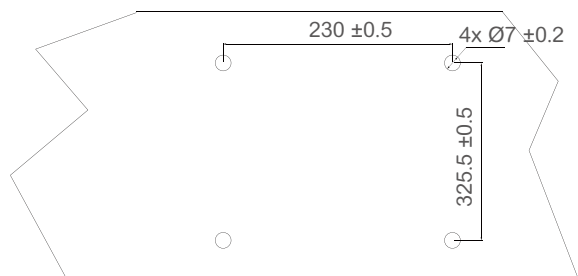

Backplane

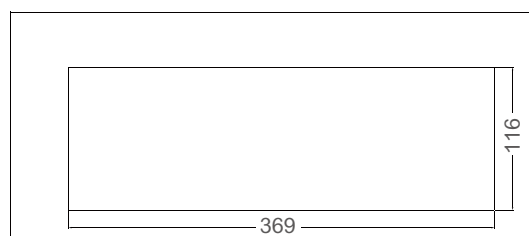

Cutout

Frame	L	W	H	A	B	C	D	E	F	G	H1	H2	H3	H4	H5	H6	H7
630	467	341	185.8	115	101.5	230	45	162	75	4.3	20.1	165.7	72.45	81.7	3	0.7	101.6

Frame	I	J	K	M	N	O	P1	P2	Q
630	300	20.7	8	27.3	270	325	30.7	24.3	8

Schneider Electric

135 Rue Joseph Monier,
92500 Rueil-Malmaison, France

Se.com

November 2023