

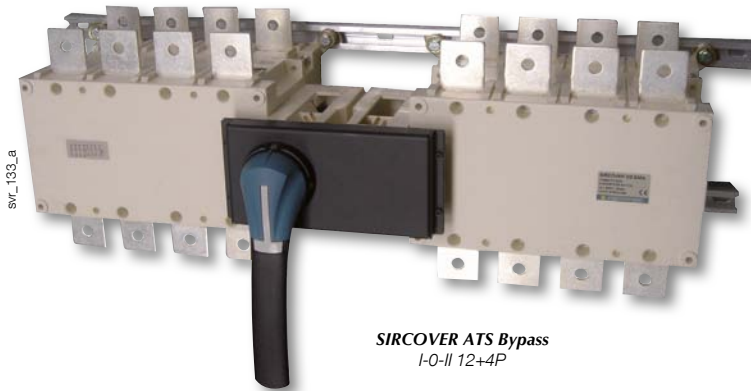

# SIRCOVER ATS Bypass

Manual transfer switches  
from 125 to 1600 A

Transfer  
switches



SIRCOVER ATS Bypass  
I-O-II 12+4P

## The solution for

- > Industry
- > Healthcare buildings



## Strong points

- > Stable positions
- > Secured breaking
- > On load switching
- > A complete solution

## Conformity to standards

- > IEC 60947-3



## Function

SIRCOVER ATS Bypass switches are manual four pole transfer switches with positive break indication. They are designed to isolate ATS type electrical equipment (automatic transfer switch) or UPS, with minimum interruption to the load supply. Integrating a SOCOMEC transfer switch into the installation enables source selection when in Bypass (see operating principle below).

## Advantages

### Stable positions

SIRCOVER ATS Bypass switches have 3 stable positions which are not affected by voltage drops or vibrations.

### On load switching

Thanks to its AC-22 characteristics, tested in accordance with standard IEC 60947-3, the SIRCOVER ATS Bypass enables on load switching.

### Secured breaking

Simultaneous upstream and downstream isolation and fully visualised breaking.

### A complete solution

The SIRCOVER ATS Bypass is a single product offering a genuine solution incorporating both an equipment isolation function and a switching function.

## Operating principle

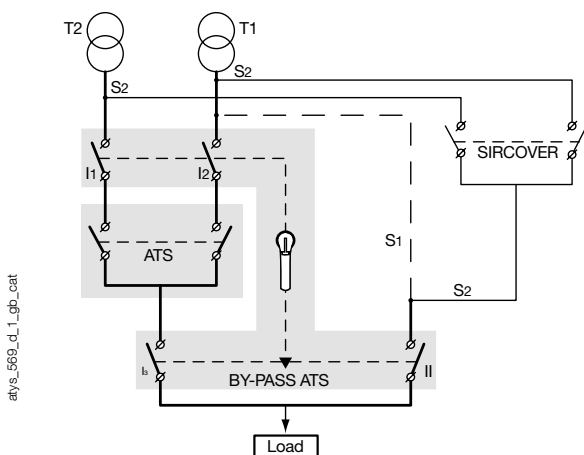

### In Bypass position:

- Without SIRCOVER: The load is supplied directly by one of the two power sources (transformer T1 for example).
- With a SIRCOVER: The supply source can be selected.

## References

Rating (A)	No. of poles	Switch body	Direct handle	External handle	Shaft for external handle	Bridging bars	Auxiliary contact	Terminal shrouds	Terminal screens
125 A	12 + 4 P	4100 <b>9813</b>	S3 type Black IP65 I - O - II 1433 <b>3113</b>	S3 type Black IP65 I - O - II 1433 <b>3113</b>	200 mm 1401 <b>1520</b>	4 P 4109 <b>4019</b>	1 <sup>st</sup> contact NO/NC included 2 <sup>nd</sup> contact NO/NC 4109 <b>0021</b> <sup>(1)</sup>	4 P 2694 <b>4014</b> <sup>(2)(3)</sup>	4 P 1509 <b>4012</b> <sup>(4)</sup>
160 A	12 + 4 P	4100 <b>9816</b>				4 P 4109 <b>4025</b>		4 P 2694 <b>4021</b> <sup>(2)(3)</sup>	4 P 1509 <b>4025</b> <sup>(4)</sup>
250 A	12 + 4 P	4100 <b>9825</b>				4 P 4109 <b>4039</b>		4 P 2694 <b>4021</b> <sup>(2)(3)</sup>	4 P 1509 <b>4025</b> <sup>(4)</sup>
400 A	12 + 4 P	4100 <b>9840</b>				4 P 4109 <b>4063</b>		4 P 2694 <b>4051</b> <sup>(2)(3)</sup>	4 P 1509 <b>4063</b> <sup>(4)</sup>
630 A	12 + 4 P	4100 <b>9863</b>				Black 2799 <b>7062</b>		Black IP65 I - O - II 2799 <b>7147</b>	Included with the external handle
800 A	12 + 4 P	4100 <b>9880</b>	4 P 4109 <b>4160</b>						
1000 A	12 + 4 P	4100 <b>9881</b>							
1250 A	12 + 4 P	4100 <b>9882</b>							
1600 A	12 + 4 P	4100 <b>9886</b>							

(1) 2 pieces: one for position I and one for position II.

(2) To fully shroud front, rear, top and bottom 3 references required.

(3) To shroud front switch top and bottom 4 references required.

(4) For complete front protection, order the reference twice.

## Accessories

### Key handle interlocking system

#### Locking in position 0 with RONIS EL11AP (lock not supplied)

Rating (A)	Operation	Figure	Reference
125 ... 630	direct	1	4109 <b>1006</b> <sup>(1)</sup>
125 ... 630	external	3	<b>1499 7701</b>
800 ... 1600	direct and external	2	Please consult us

(1) Specific handle included.

#### Locking in positions I, O, II with RONIS EL11AP (lock not supplied)

Rating (A)	Operation	Figure	Reference
125 ... 630	direct	1	4109 <b>1002</b> <sup>(1)</sup>
800 ... 1600	direct	2	Please consult us

(1) Specific handle included.

#### Locking with CASTELL K type lock (lock not supplied)

Rating (A)	Operation	Figure	Reference
125 ... 630	external	3	<b>1499 7702</b>
800 ... 1600	external		Please consult us

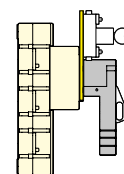

Fig. 1



Fig. 2

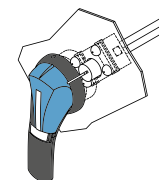

Fig. 3

access\_001\_a\_1\_x\_cat

access\_132\_a\_1\_x\_cat

access\_156\_a\_1\_x\_cat

# SIRCOVER ATS Bypass

Manual changeover switches

from 125 to 1600 A

## Characteristics according to IEC 60947-3

125 to 1600 A

Thermal current $I_{th}$ at 40°C	125 A	160 A	250 A	400 A	630 A	800 A	1000 A	1250 A	1600 A
Rated insulation voltage $U_i$ (V)	800	800	800	800	1000	1000	1000	1000	1000
Rated impulse withstand voltage $U_{imp}$ (kV)	8	8	8	8	12	12	12	12	12

### Rated operational currents $I_e$ (A)

Rated voltage	Utilisation category	A/B <sup>(1)</sup>	A/B <sup>(1)</sup>	A/B <sup>(1)</sup>	A/B <sup>(1)</sup>	A/B <sup>(1)</sup>	A/B <sup>(1)</sup>	A/B <sup>(1)</sup>	A/B <sup>(1)</sup>	A/B <sup>(1)</sup>
415 VAC	AC-20 A / AC-20 B	125/125	160/160	250/250	400/400	630/630	800/800	1000/1000	1250/1250	1600/1600
415 VAC	AC-21 A / AC-21 B	125/125	160/160	250/250	400/400	630/630	800/800	1000/1000	1250/1250	1600/1600
415 VAC	AC-22 A / AC-22 B	125/125	160/160	250/250	400/400	630/630	800/800	1000/1000	1250/1250	1600/1600
415 VAC	AC-23 A / AC-23 B	125/125	160/160	250/250	250/250	500/500	800/800	1000/1000	1250/1250	1250/1250
690 VAC <sup>(2)</sup>	AC-20 A / AC-20 B	125/125	160/160	250/250	400/400	630/630	800/800	1000/1000	1250/1250	1600/1600
690 VAC <sup>(2)</sup>	AC-21 A / AC-21 B	125/125	160/160	200/250	200/250	500/500	800/800	800/800	800/800	1000/1000
690 VAC <sup>(2)</sup>	AC-22 A / AC-22 B	125/125	125/125	125/160	125/160	315/315	800/800	800/800	800/800	1000/1000
690 VAC <sup>(2)</sup>	AC-23 A / AC-23 B	63/80	63/80	100/125	100/125	160/200	200/250	200/250	200/250	500/500
220 VDC	DC-20 A / DC-20 B	125/125	160/160	250/250	400/400	630/630	800/800	1000/1000	1250/1250	1600/1600
220 VDC	DC-21 A / DC-21 B	125/125	160/160	250/250	250/250	630/630	800/800	1000/1000	1250/1250	1250/1250
220 VDC	DC-22 A / DC-22 B	125/125	160/160	250/250	250/250	500/500	800/800	1000/1000	1250/1250	1250/1250
220 VDC	DC-23 A / DC-23 B	125/125	125/125	200/200	200/200	500/500	800/800	1000/1000	1250/1250	1250/1250
440 VDC	DC-20 A / DC-20 B	125/125	160/160	250/250	400/400	630/630	800/800	1000 <sup>(4)</sup> /1000 <sup>(4)</sup>	1250/1250	1600/1600
440 VDC	DC-21 A / DC-21 B	125 <sup>(3)</sup> /125 <sup>(3)</sup>	125 <sup>(3)</sup> /125 <sup>(3)</sup>	200 <sup>(3)</sup> /200 <sup>(3)</sup>	200 <sup>(3)</sup> /200 <sup>(3)</sup>	500 <sup>(3)</sup> /500 <sup>(3)</sup>	800 <sup>(4)</sup> /800 <sup>(4)</sup>	1000 <sup>(4)</sup> /1000 <sup>(4)</sup>	1250 <sup>(4)</sup> /1250 <sup>(4)</sup>	1250 <sup>(4)</sup> /1250 <sup>(4)</sup>
440 VDC	DC-22 A / DC-22 B	125 <sup>(3)</sup> /125 <sup>(3)</sup>	125 <sup>(3)</sup> /125 <sup>(3)</sup>	200 <sup>(3)</sup> /200 <sup>(3)</sup>	200 <sup>(3)</sup> /200 <sup>(3)</sup>	500 <sup>(3)</sup> /500 <sup>(3)</sup>	800 <sup>(4)</sup> /800 <sup>(4)</sup>	1000 <sup>(4)</sup> /1000 <sup>(4)</sup>	1250 <sup>(4)</sup> /1250 <sup>(4)</sup>	1250 <sup>(4)</sup> /1250 <sup>(4)</sup>
440 VDC	DC-23 A / DC-23 B	125 <sup>(4)</sup> /125 <sup>(4)</sup>	125 <sup>(4)</sup> /125 <sup>(4)</sup>	200 <sup>(4)</sup> /200 <sup>(4)</sup>	200 <sup>(4)</sup> /200 <sup>(4)</sup>	500 <sup>(4)</sup> /500 <sup>(4)</sup>	800 <sup>(4)</sup> /800 <sup>(4)</sup>	1000 <sup>(4)</sup> /1000 <sup>(4)</sup>	1250 <sup>(4)</sup> /1250 <sup>(4)</sup>	1250 <sup>(4)</sup> /1250 <sup>(4)</sup>

### Operational power in AC-23 (kW)

At 400 VAC without pre-break in AC <sup>(1)(5)</sup>	63/63	80/80	132/132	132/132	280/280	450/450	710/710	710/710	710/710
At 690 VAC without pre-break in AC <sup>(1)(5)</sup>	55/75	55/75	90/110	90/110	150/185	185/220	185/220	185/220	475/475

### Reactive power (kvar)

At 400 VAC <sup>(5)</sup>	55	75	115	185	290	365	575	575	
---------------------------	----	----	-----	-----	-----	-----	-----	-----	--

### Fuse protected short-circuit withstand (kA rms prospective)

Prospective short-circuit (kA rms) <sup>(6)</sup>	100	100	50	18	70	50	100	100	100
Associated fuse rating (A) <sup>(6)</sup>	125	160	250	400	630	800	1000	1250	2 x 800

### Circuit breaker protected short-circuit withstand with any circuit breaker that ensures tripping in less than 0.3s<sup>(7)</sup>

Rated short-time withstand current 0.3s l <sub>cw</sub> (kA rms)	15	15	17	17	25	50	65	65	100
--	----	----	----	----	----	----	----	----	-----

### Short-circuit capacity (without protection)

Thermal current $I_{th}$ at 40°C	125 A	160 A	250 A	400 A	630 A	800 A	1000 A	1250 A	1600 A
Rated short-time withstand current 1s l <sub>cw</sub> (kA rms)	8	8	9	9	14	27	36	36	50
Rated short-circuit making capacity								75	75

### Connection

Minimum Cu cable cross-section (mm <sup>2</sup> )	35	50	95	185	2 x 150	2 x 185			
Minimum Cu busbar cross-section (mm <sup>2</sup> )					2 x 30 x 5	2 x 40 x 5	2 x 60 x 5	2 x 60 x 5	2 x 80 x 5
Maximum Cu cable cross-section (mm <sup>2</sup> )		50	95	150	240	2 x 300	2 x 300	2 x 300	4 x 185
Maximum Cu busbar width (mm)	25	25	32	32	50	63	63	63	100
Tightening torque min (Nm)	9	9	20	20	20	20	20	20	40

### Mechanical characteristics

Durability (number of operating cycles)	10000	10000	10000	10000	5000	3000	3000	3000	3000
Weight of 3 P switch (kg)	8.3	8.3	10	10.3	20.7	44.3	45.4	46.4	54.7
Weight of 4 P switch (kg)	10.6	10.6	11.7	12.4	24.8	53	54.4	55.8	67.3

(1) Category with index A = frequent operation

Category with index B = infrequent operation.

(2) With terminal shrouds.

(3) 3-pole device with 2 poles in series for the "+" and 1 pole for the "-".

(4) 4-pole device with 2 poles in series per polarity.

(5) The power value is given for information only, the current values vary from one manufacturer to another.

(6) For a rated operational voltage  $U_n = 400$  VAC.

(7) Value for coordination with any circuit breaker that ensures tripping in less than 0.3s. For coordination with specific circuit-breaker references, higher short-circuit current values are available. Please consult us.

## Connection terminals

### SIRCOVER ATS Bypass 800 to 1000 A

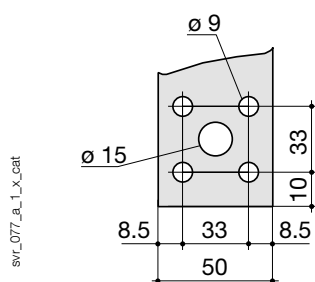

### SIRCOVER ATS Bypass 1250 to 1600 A

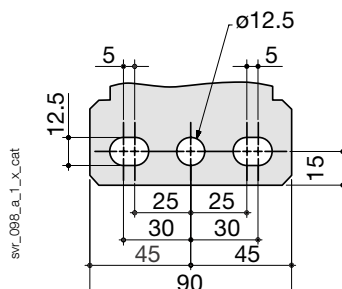

## Dimensions

### SIRCOVER ATS Bypass 125 to 630 A

Direct front operation

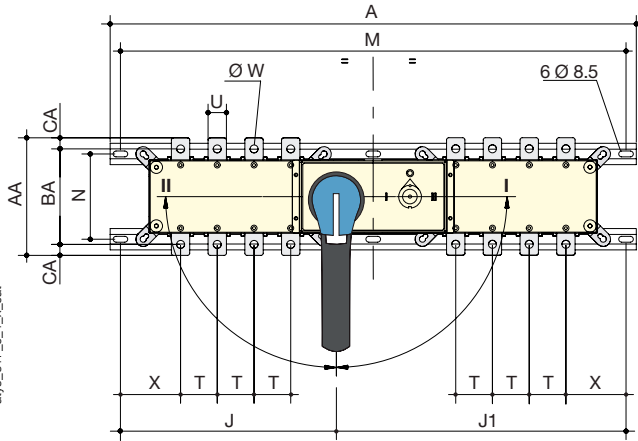

External front operation

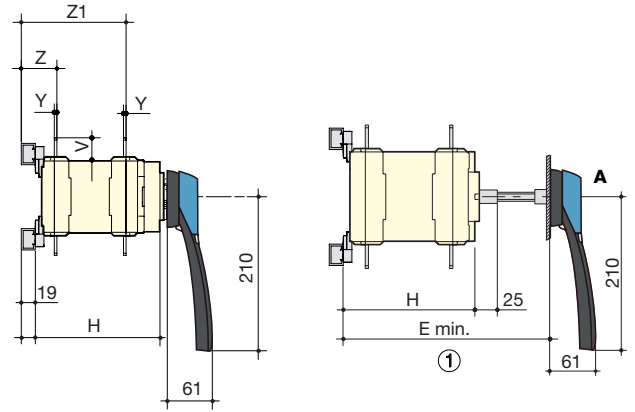

A. S3 type handle for external front operation: 125 to 630 A.  
1. Max length with shaft extension: E min + 50 mm.

Rating (A)	Overall dimensions		Switch body				Switch mounting			Connection								
	A 8p.	E min	H	J 8p.	J1 8p.	M 8p.	N	T	U	V	W	X 8p.	Y	Z	Z1	AA	BA	AC
125	610	260±1	193	238	338	576	101	36	20	25	8.5	76	3.5	47	143	135	115	10
160	610	260±1	193	238	338	576	101	36	20	25	8.5	76	3.5	47	143	135	115	10
250	725	260±1	193	295	396	691	116	50	25	30	11	83.5	3.5	49	143	160	130	10
400	725	260±1	193	295	396	691	116	50	35	35	11	83.5	3.5	49	143	170	140	15
630	850	337±1	270	358	458	816	176	65	45	50	13	91.5	5	62	199	235	220	20

### SIRCOVER ATS Bypass 800 to 1600 A

Direct front operation

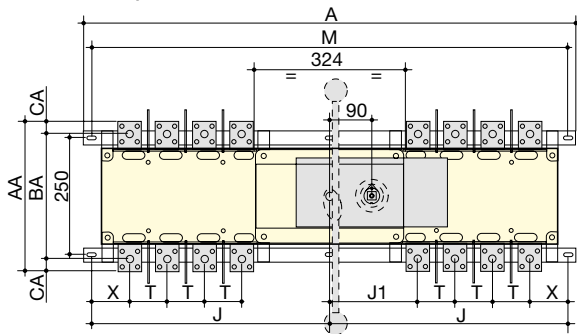

External front operation

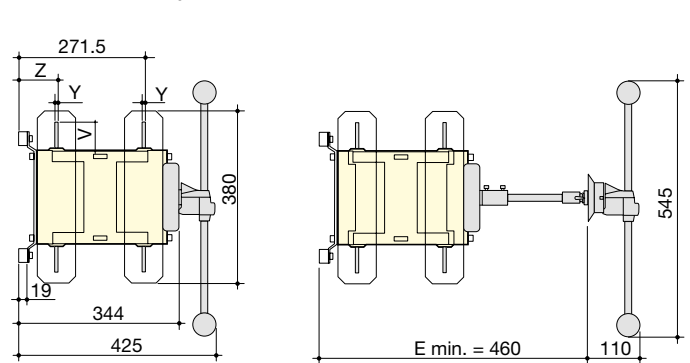

Rating (A)	Overall dimensions		Switch body			Switch mounting		Connection					
	A 8p.	J 8p.	J1 8p.	M 8p.	T	V	X 8p.	Y	Z	AA	BA	AC	
800	1 055	510.5	189	1 021	80	60.5	81.5	7	84.5	321	268	26.5	
1000	1 055	510.5	189	1 021	80	60.5	81.5	7	84.5	321	268	26.5	
1250	1 320	643	195	1 286	120	44	88	8	85.5	288	258	15	
1600	1 320	643	195	1 286	120	44	88	8	85.5	288	258	15	

## Dimensions for external handles

### SIRCOVER ATS Bypass 125 to 630 A

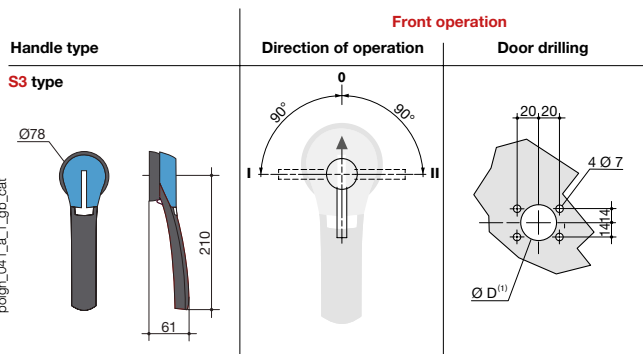

### SIRCOVER ATS Bypass 800 to 1600 A

